



SUMITOMO™ WIRES

Sumitomo™

PREMIUM EDM BRASS WIRE

SPECIAL FEATURES

- Cleanliness
- Straightness
- Consistent Cutting Performance
- Faster Cutting Speed
- Paraffin Free
- Made from Japanese Virgin Raw Materials

EXCLUSIVELY MANUFACTURED FOR GLOBAL EDM SUPPLIES, INC.
MANUFACTURED BY SUMITOMO ELECTRIC



GLOBAL EDM
S U P P L I E S

TYPES OF WIRE

SUMITOMO™ SBS

GRADE	COMPOSITION	DIAMETER	TOLERANCE	TENSILE STRENGTH
SBS-H	Standard Brass	0.10mm-0.33mm	±0.002mm	930-1080 N/mm ²
SBS-A	Standard Brass	0.10mm-0.33mm	±0.002mm	440-585 N/mm ²

SBS Premium Brass Product for WEDM

SUMITOMO™ SBG

GRADE	COMPOSITION	DIAMETER	TOLERANCE	TENSILE STRENGTH
SBG-H	High Zinc Brass	0.10mm-0.33mm	±0.001mm	930-1080 N/mm ²
SBG-A	High Zinc Brass	0.10mm-0.33mm	±0.001mm	440-585 N/mm ²

SBG High Zinc Brass Product for speed

SUMITOMO™ SS

GRADE	COMPOSITION	DIAMETER	TOLERANCE	TENSILE STRENGTH
SS-H	Cu:Zn alloy with other elements	0.07mm-0.33mm	±0.001mm	1030-1200 N/mm ²
SS-A	Cu:Zn alloy with other elements	0.10mm-0.33mm	±0.001mm	440-585 N/mm ²

SS Specialty Brass Products for cutting thick work piece, aluminum alloy, and titanium etc...
Available upon request only



QUALITY MANUFACTURING

Sumitomo EDM wires are produced under a Strict Quality Controlled environment and conditions established by Sumitomo Electric and therefore are assured of impurity free materials, high dimensional precision, stable mechanical performance, clean and smooth surface quality, perfect straightness without any curl and twists and built-in capability to achieve high cutting speed.

These wires have been produced in close collaboration with well renowned Japanese EDM machine manufacturers to develop products that can provide optimum machine performance. These wires are recommended by most Japanese EDM machine manufacturers.

WIRE RECOMMENDATION GUIDE

WEDM	STANDARD CUTTING	TAPER CUTTING	THICK MATERIAL CUTTING	HIGH SPEED CUTTING
MITSUBISHI	SBS-H	SBS-A	SS-H	SBG-H
CHARMILLES	SBS-H/SBS-A	SBS-A	SS-H	SBG-H
AGIE	SBS-H	SBS-A	SS-H	SBG-H
SODICK	SBG-H	SBS-A	SS-H	SBG-H
FANUC	SBS-H	SBS-A	SS-H	SBG-H

WIRE SUBSTITUTION GUIDE

SUMITOMO	OKI	HITACHI	FURUKAWA	BEDRA
SBS-H	OKI-P	HBZ-K	FBH	MEGACUT
SBS-A	OKI-B	ABZ	FBA	MEGACUT
SBG-H	PZN, PX	n/a	n/a	n/a
SBG-A	PZN, PX	n/a	n/a	n/a
SS-H	OKI-H	n/a	FKH	SOMSAL
SS-A	n/a	n/a	n/a	n/a

SPOOL, WEIGHT & PACKING

Spool Type	Dimension (mm)					Std. wt. lbs/kg	Spool/ Box
	D ¹	D ²	W ¹	W ²	d		
P3	130	80	110	90	20	6.6/3.0	6
P5	160	90	114	90	20	11.0/5.0	4
P10	200	90	134	110	25	22.0/10.0	2
P20	250	110	140	110	34	44.0/20.0	1
DIN125	125	80	125	100	16	7.7/3.5	4
DIN160	160	100	160	128	22	17.6/8.0	2
DIN200	200	125	200	160	22	35.2/15.0	1
DIN250	n/a	n/a	n/a	n/a	n/a	55.0/25.0	1

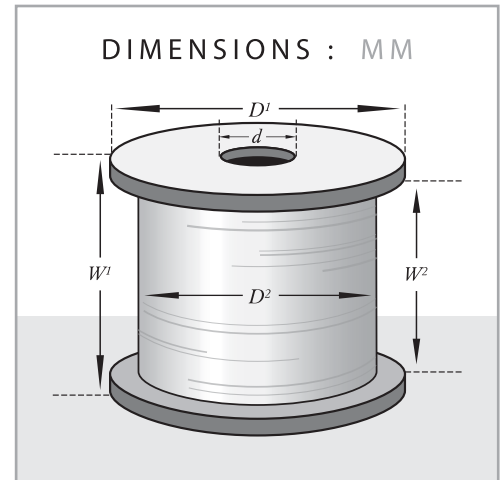

LENGTH PER SPOOL

Wire Diameter (mm)	Japan Standard						European Standard		
	3.0kg	5.0km	10.0km	20.0kg	30.0kg	50.0kg	3.5kg	8.0kg	15.0kg
	6.6lbs	11.0lbs	22.0lbs	44.0lbs	66.0lbs	110.0lbs	7.7lbs	17.6lbs	35.2lbs
0.07	n/a	n/a	n/a	n/a	n/a	n/a	109.2km	n/a	n/a
0.10	45.9km	n/a	n/a	n/a	n/a	n/a	53.6km	n/a	n/a
0.15	20.4km	34.0km	n/a	n/a	n/a	n/a	23.8km	54.4km	n/a
0.20	11.5km	19.1km	38.0km	76.0km	114.0km	191.0km	13.3km	30.4km	57.3km
0.25	7.3km	12.2km	24.4km	48.8km	73.2km	122.0km	8.8km	20.0km	36.6km
0.30	5.1km	8.5km	17.0km	34.0km	51.0km	85.0km	n/a	13.6km	25.5km
0.33	n/a	7.0km	14.0km	28.0km	42.0km	70.0km	n/a	11.2km	21.0km

CORPORATE OFFICE-Global EDM Supplies Inc.
1111 Western Row Road, Mason, OH 45040

CONNECTICUT OFFICE-Global EDM Supplies, Inc.
411 John Downey Drive, New Britain, CT 06051

TEL ▶ 800.708.1345
FAX ▶ 513.573.9919

TEL ▶ 800.290.7573
FAX ▶ 800.211.8886