

A photograph of several spools of Hitachi EDM wires. The spools are made of clear plastic and are filled with a dense, golden-colored wire. The wires are tightly packed and reflect light, giving them a metallic sheen. The spools are arranged in a row, with the one in the foreground being the most prominent. The background is dark, making the spools stand out.

HITACHI WIRES

SPECIAL FEATURES

Paraffin Free

Exceptional Cleanliness

Superior Straightness For Consistent Threading

Zinc Enriched Brass For Faster Cutting Speed

Produced From Virgin Raw Materials



GLOBAL EDM
S U P P L I E S

TYPES OF WIRE

HITACHI-HBZ-K

GRADE	COMPOSITION	DIAMETER	TOLERANCE	TENSILE STRENGTH
HBZ-K Hard	60% Copper / 40% Zinc	.1mm-.33mm	+0/--.002mm	980 N/mm ²

HITACHI-ABZ

GRADE	COMPOSITION	DIAMETER	TOLERANCE	TENSILE STRENGTH
ABZ Soft	65% Copper / 35% Zinc	.2mm-.33mm	+0/--.002mm	440 N/mm ²

SPOOL : WEIGHT & PACKING

Spool Type	Dimension (mm)				Std. wt. kg	Spool/ Box
	D ¹	D ²	W ¹	d		
P-3R	130	80	110	20	3.0	6
P-5R	160	90	114	20	5.0	4
P-5RX	160	90	114	20	6.0	4
P-5X	160	70	114	20	6.8	4
P-10	200	90	134	25	10.0	1
P-15L	250	110	140	34	20.0	1
P-30	280	200	220	73	30.0	1
P-50	320	162	217	34	50.0	1
DIN125	125	80	125	16	3.0	4
DIN160	160	100	160	22	6.0	2
DIN200	200	125	200	22	15.0	1

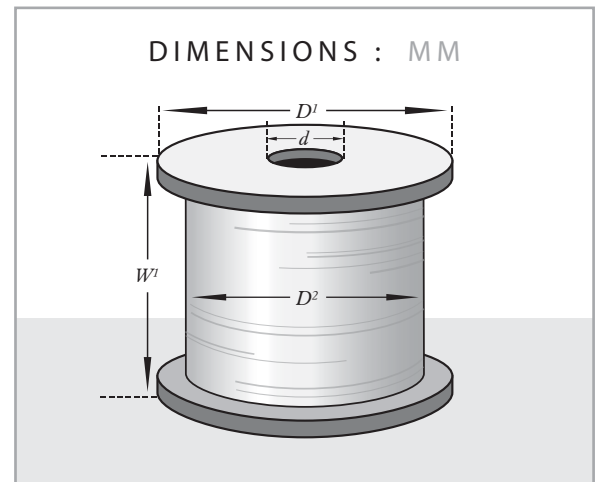

CORPORATE OFFICE - Global EDM Supplies Inc.
1111 Western Row Road, Mason, OH 45040

OPERATIONS CENTER - Global EDM Supplies, Inc.
411 John Downey Drive, New Britain, CT 06051

TEL ▶ 800.708.1345
FAX ▶ 513.701.0457

TEL ▶ 800.290.7573
FAX ▶ 800.211.8886